

# PULSA® Series

## Diaphragm Metering Pumps

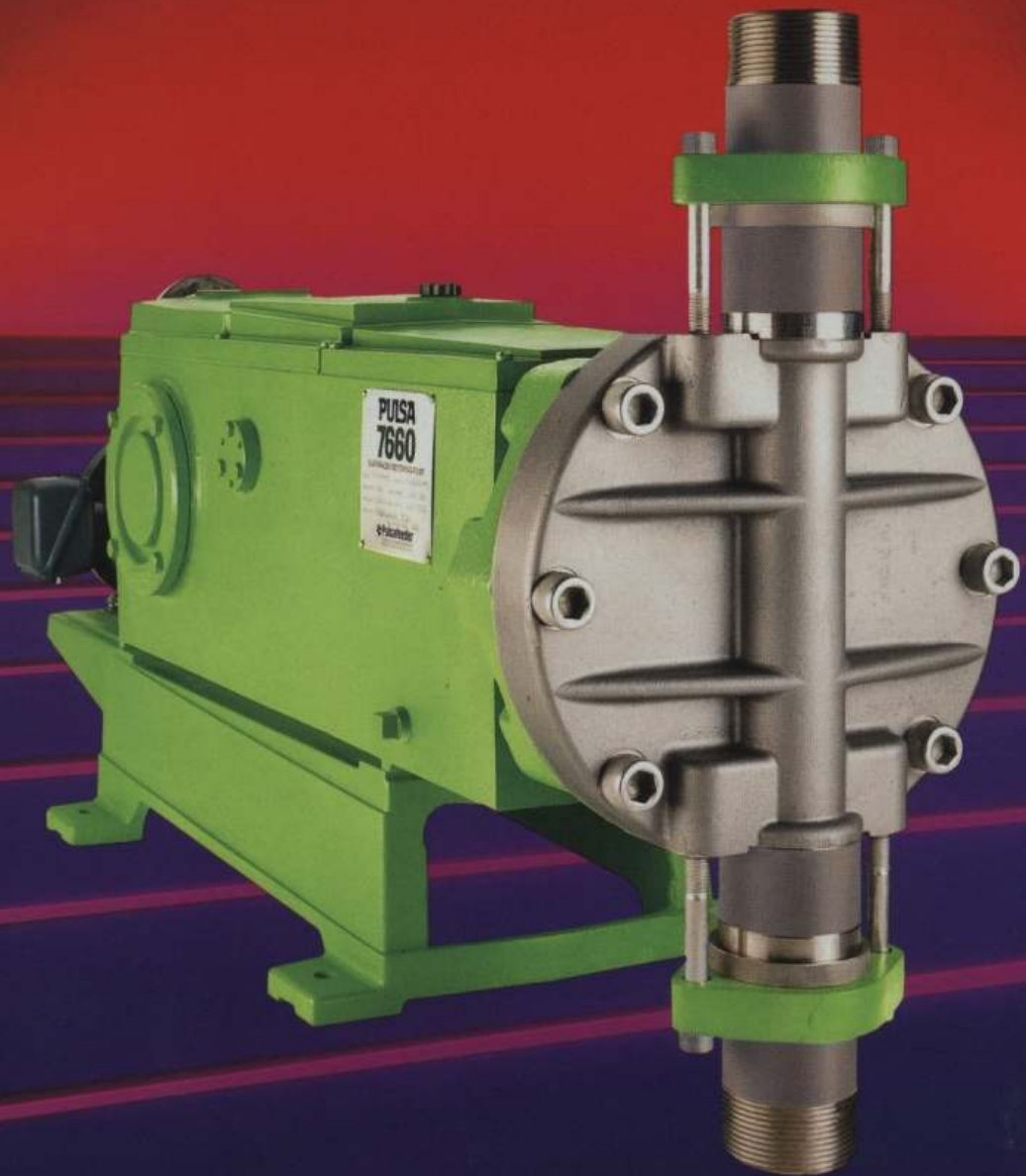

## Designed For Metering Precision And Dependability

Although the details of operation vary, the general principle is similar for all PULSA Series metering pumps. Here's a summary of how they work and why they're the first choice of people who put the emphasis on quality, serviceability and economical cost of ownership.

- The pump drive mechanism transmits a reciprocating action to a piston operating in a hydraulic reservoir. The piston's forward movement transmits hydraulic force against a diaphragm/membrane separating the pumping mechanism from the liquid being pumped. The diaphragm moves in direct relationship to the piston and displaces process liquid through the

- Diaphragms and heads are available in a variety of materials to meet any corrosive pumping problem.
- Because the motion of the diaphragm can be precisely controlled by the drive mechanism, the pumping rate can be metered with exceptional accuracy.
- Fail-safe protection is built in. Three automatic valves keep the entire system hydraulically balanced for trouble-free operation.
  1. A make-up valve permits the flow of replacement oil from the oil reservoir to the area between the plunger and the diaphragm.

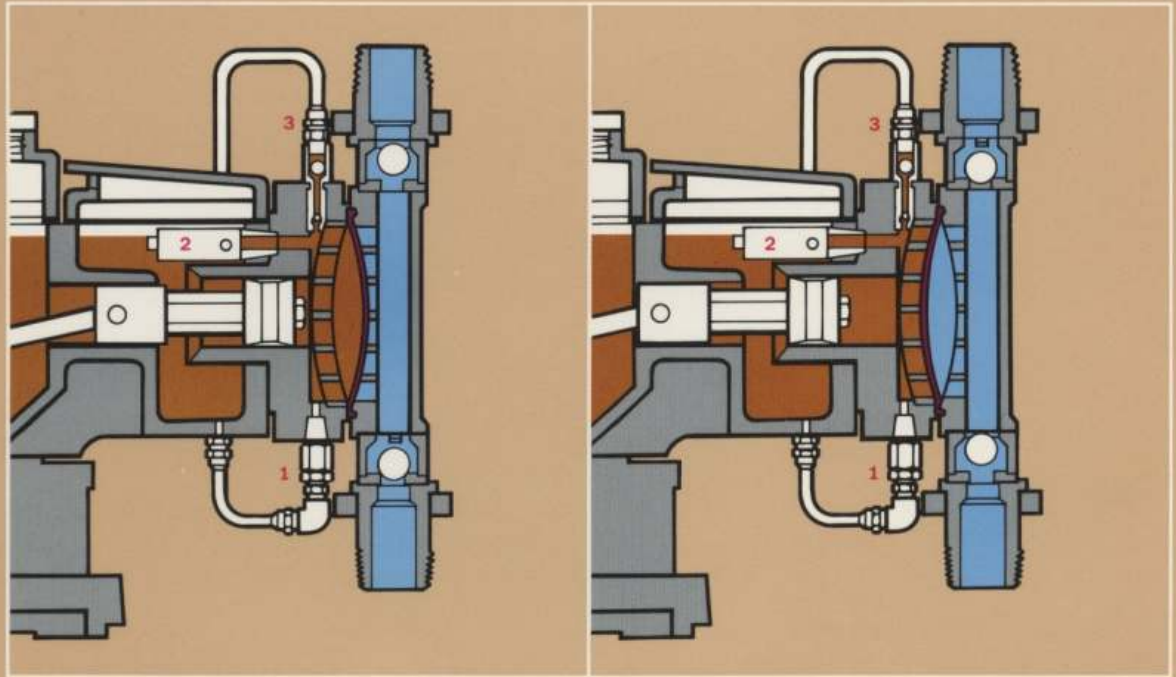

outlet check valve. Backward movement of the piston reverses the cycle allowing fresh liquid to enter the metering head through the inlet check valve.

- Since the diaphragm has no mechanical attachment it is **HYDRAULICALLY BALANCED** and stress free. When the diaphragm is working within the recommended temperature range, it is immune to the effects of corrosion and abrasion. These features work together to give the diaphragm an unlimited life.

2. A by-pass valve releases oil and terminates the hydraulic pumping action when the oil ahead of the plunger is under excess pressure from accidental line stoppage. This is a built-in safety mechanism that protects the pump.
3. A bleeder valve automatically and continuously releases any entrained air or oil vapors to maintain a "hard" hydraulic system.

## The Economical Hydratube® Is Ideal For High Viscosities And High Density Slurries

The large, straight-thru flow path of the HYDRATUBE® eliminates flow restrictions and clogging. The HYDRATUBE® head is very economical because the process fluid only comes in contact with the tubular diaphragm and check valves. The design eliminates the need for costly high-alloy head materials.

Our economical tubular diaphragm in elastomer materials can handle a broad range of corrosive or erosive liquids.



Our Teflon® PFA HYDRATUBE® is available for applications where solvents, amines or other liquids are incompatible with elastomers.

The primary diaphragm of the HYDRATUBE® head is normally made of elastomers, but PTFE is also available. It can provide an extra measure of protection for pumping sulphuric acid and other hard-to-handle fluids.

## The PULSA Series Has A Head For Problem Solving

### Hydratube®

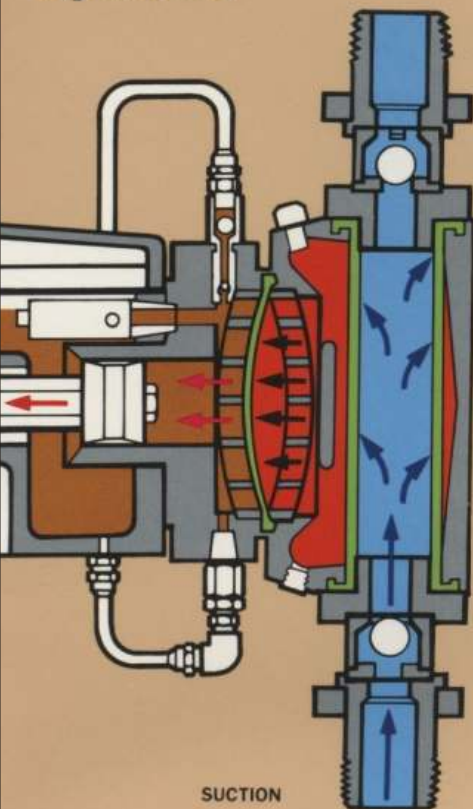

FLOWS TO 787 GPH, PRESSURES TO 600 PSI

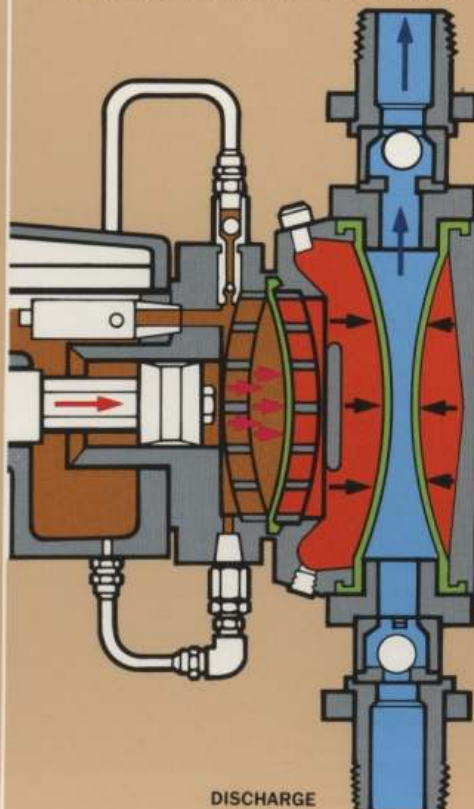

## Let The Popular Hydracone® Handle Lower Flow-Rate Pumping Tasks

The HYDRACONE® liquid end offers hydraulic diaphragm pumping precision at a very affordable price for flow rates up to 32.6 gal/hr and pressures to 1200 psi. The PULSA 680, 340 and RI models are all available with the HYDRACONE®. This self-priming head features a conical elastomer diaphragm and is particularly suited for high-lift conditions, high viscosities and low density slurries. Some of its many applications include addition of corrosion inhibitors to water supplies, metering pesticides to irrigation water and injection of plating solutions for metal and glass finishing. The HYDRACONE® diaphragm is available in a choice of high performance elastomers.



### High-Precision Valves Reduce Down Time

PULSA Series valves are designed for precise dependable pumping and for fast, easy service.

- Ball type valves are manufactured to the highest degree of sphericity for precise seating and metering accuracy.
- The ball chamber has a wide-clearance flow-path with controlled rise and four-point guiding to assure good valve action and valve seat life.
- Equally precise disc valves are offered for high-flow applications where the mass of a large ball causes noise and reduced operating life.
- Valves are compression sealed with a contained O-ring. Removal of two bolts is all that is required for service.
- In most instances, they can be removed and serviced without dismantling the piping.
- A high clearance, resilient seat valve is available for slurry application.

Hydracone®

FLOWS TO 32.6 GPH, PRESSURES TO 1200 PSI

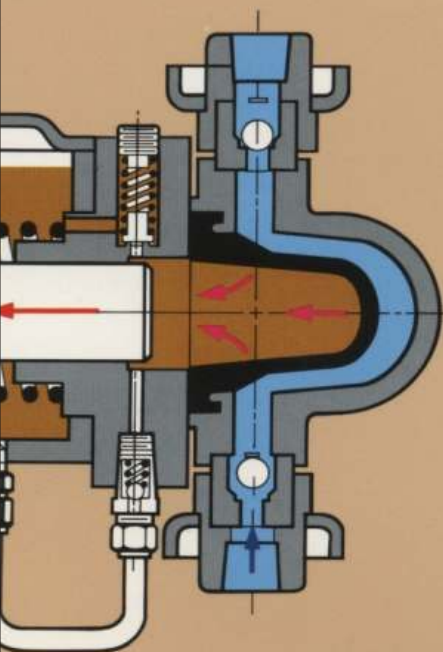

SUCTION

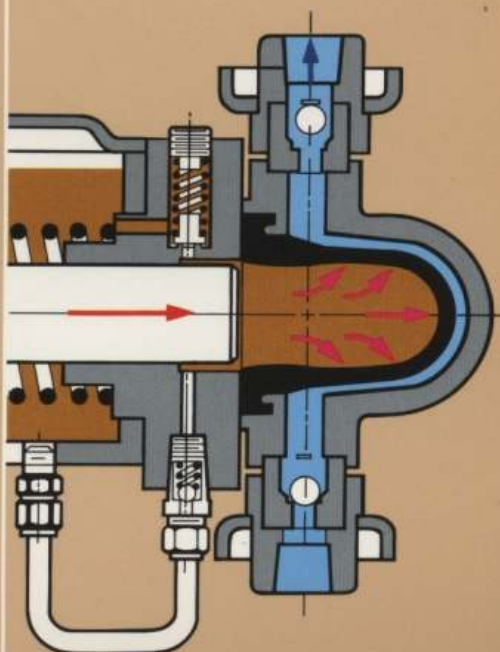

DISCHARGE

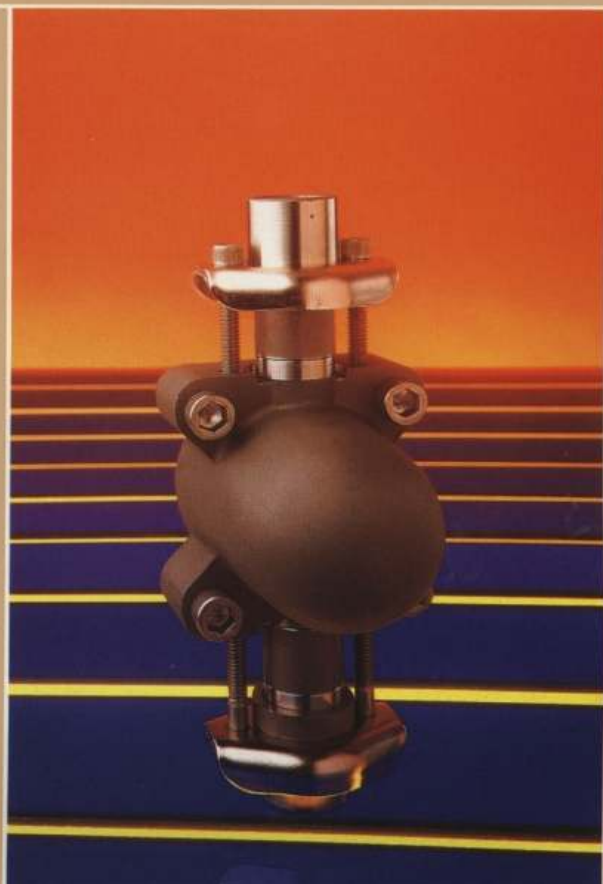

## The Versatile Flat Diaphragm Reagent Head... Our Most Popular Design

This easily primed, flow through head is a favorite for countless applications. Typical construction is 316 stainless steel with PTFE diaphragm. Head and valves are available in alternative materials.

- #20 Stainless Steel
- Alloy C
- Monel
- Nickel
- PVC
- PTFE
- Polypropylene
- Other high alloy materials

Diaphragms are also available in a variety of metal alloys and other plastics. The metal diaphragms are recommended for high temperature conditions or for handling radioactive or gaseous materials.

The metering head design permits tightening to maximum bolt torque without stressing the diaphragm material. The heads have no pipe thread connections to fail from galling or crevice corrosion, so a major source of leakage and service problems is eliminated.

### Flat Diaphragm

FLOWS TO 1445 GPH, PRESSURES TO 5000 PSI

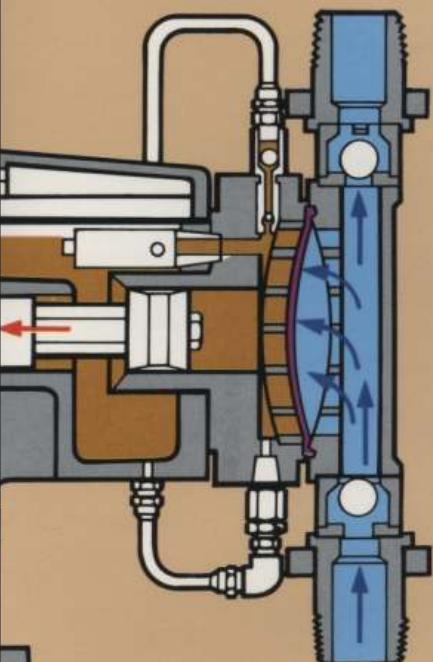

SUCTION

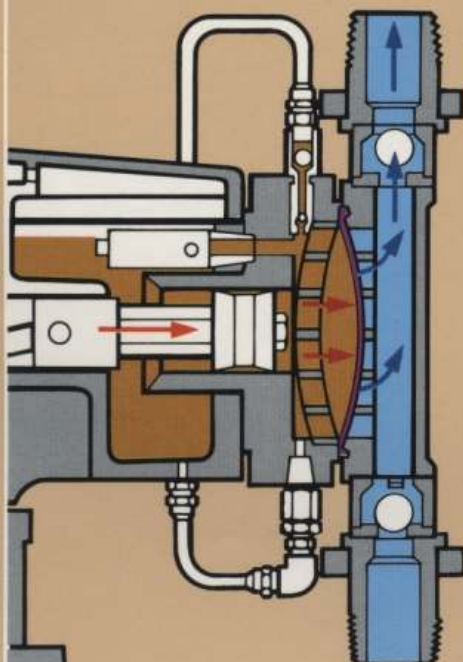

DISCHARGE



## We Back Up Our Pumping Heads With The Finest Drive Mechanisms

PULSA Series pumps are well known for their rugged construction and years of dependable performance. All internal parts are manufactured to the highest standards. Years of refinement have produced a design that's not only reliable and efficient, but exceptionally easy to service. The PULSA Series Models 7120, 7440, 7660 and 8480 all use the type of drive mechanism shown below.

- The pump mechanism functions under flooded lubrication within a large sealed reservoir for wear-free operation.
- Durability is increased through the use of high quality materials in the drive train. The worm is of hardened and polished steel, and the worm gear is made from DYNALLOY® bronze typical of high quality speed reducers.
- The life of the pump is also extended by the use of tapered roller bearings.
- Each major component of the drive and stroke length mechanism is available for quick inspection or service without major disassembly of other parts.
- The unique sealed cover with diaphragm breather allows the reciprocating mechanism to breathe without introducing outside air and environmental contaminants into the hydraulic and lubrication reservoir.

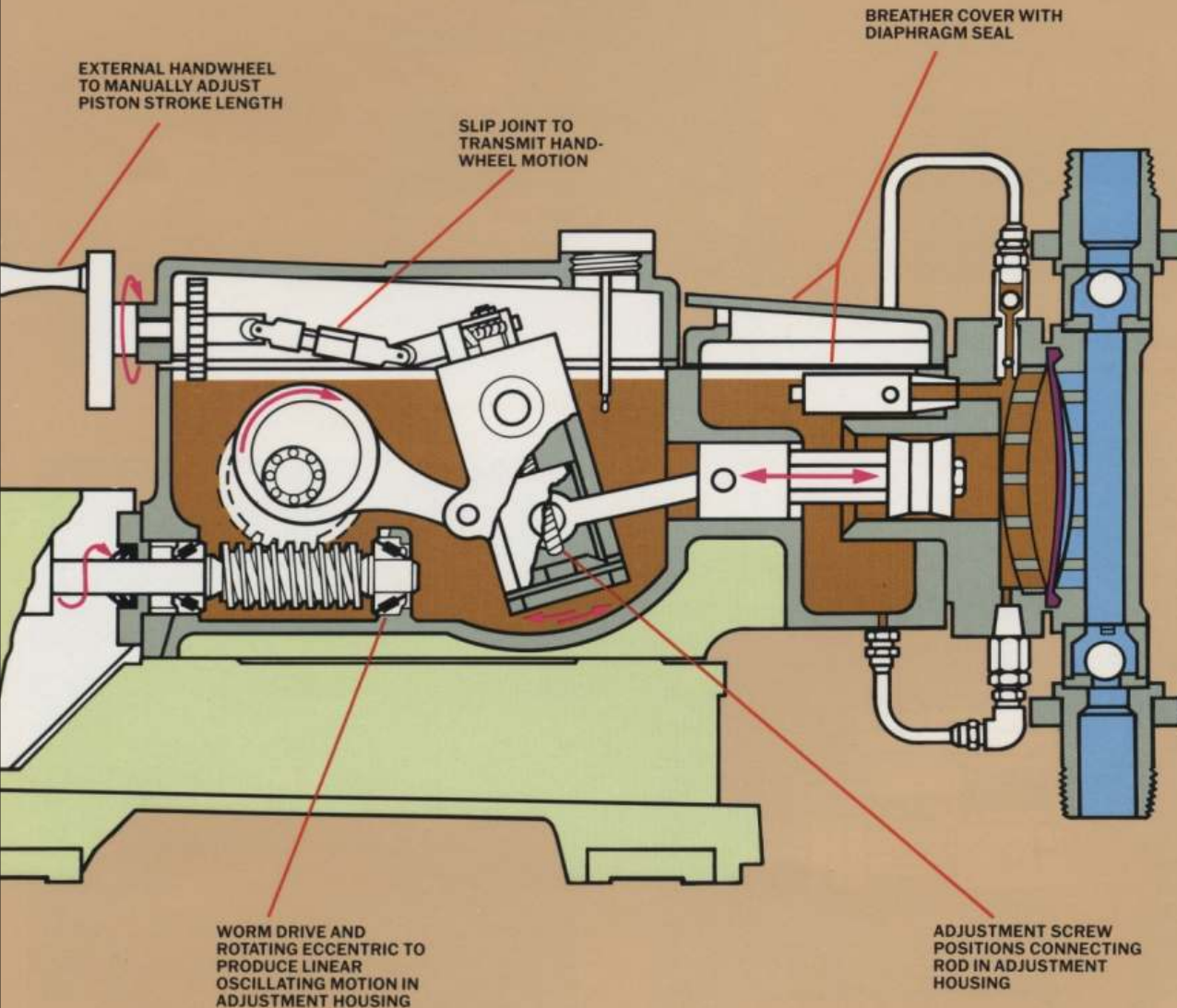

**Three Compact,  
Economical  
Members Of The  
PULSA Series**



**Mechanical Lost Motion Style**

Four smaller pumps in the PULSA Series, the 200, 340, 680 and 880, use a simple mechanical lost motion style stroke length adjustment. This arrangement offers exceptional economy and serviceability.

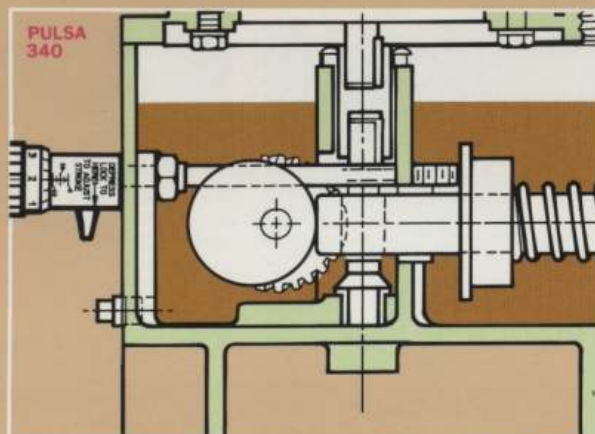

Stroke length of the plunger is controlled by micrometer positioning of a screw to limit movement of the plunger as it follows the driver cam. The PULSA 340 uses a one piece plunger cross-head for ultimate simplicity and economy.

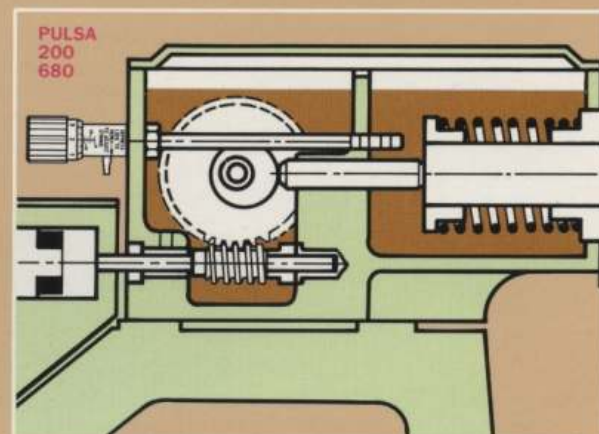

The PULSA 200 and 680 offer a broader interchangeability of plungers and incorporates a two-piece plunger/cross-head design.

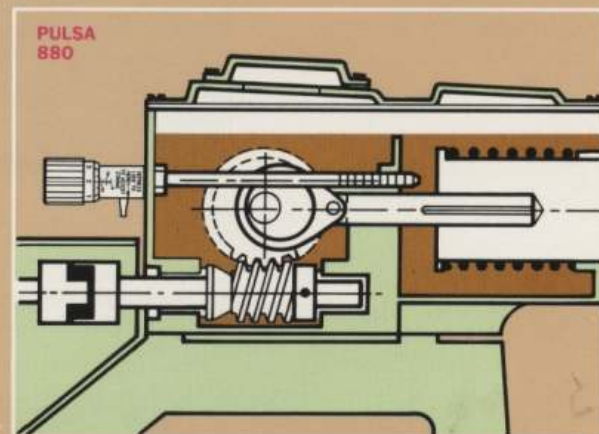

PULSA 880 metering pumps produce flows approaching 100 GPH. A unique hydraulic dampener built into the plunger softens the engagement of the drive to the plunger . . . an innovative feature not found in competitive models.

## Unlimited Flexibility

Many applications require more than a standard PULSA Series pump to deal with unique pumping problems. For these situations, complete engineering support can prove invaluable. Our staff of experts can create a specific pumping unit that can maximize output and safety and minimize cost. Here are some examples of PULSA Series versatility.



PULSA Series pumps can be joined together in efficient multi-pump configurations. In the duplex arrangement shown here, a 7120-D-E is equipped with a metal head and PTFE diaphragm. This is the type of pump that would be used to ratio two fluids to a common stream.



The PULSA 7120H shown here features a HYDRATUBE® head, pneumatic stroke length adjustment and Chemalarm leak detector. A typical application is the addition of concentrated sulphuric acid to a water stream using automatic flow control.

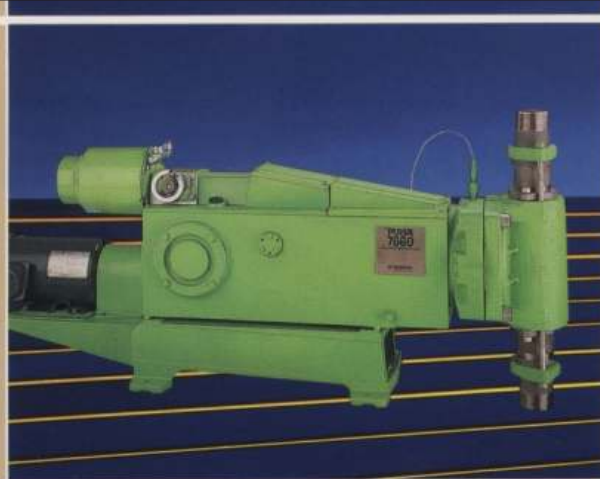

The PULSAmatic control shown on this PULSA 7660H HYDRATUBE® pump provides 0 to 100% electric stroke length control from an analog instrument signal.



A PULSA Series 880 is shown here with an ELMA electric stroke length control and a nonmetallic head. A typical application is the automated addition of hydrochloric acid using an analog instrument signal.



From the largest job to the smallest, the PULSA Series can handle a wide variety of pumping assignments. The PULSA 8480 can provide flow rates up to 1500 gal/hr. The versatile PULSA 680C, shown here with a HYDRACONE® head and pneumatic control, is ideal for high-accuracy, low-capacity tasks.

## Special Features For Unusual Pumping Conditions

The PULSA Series can be equipped to perform in a variety of demanding environments.

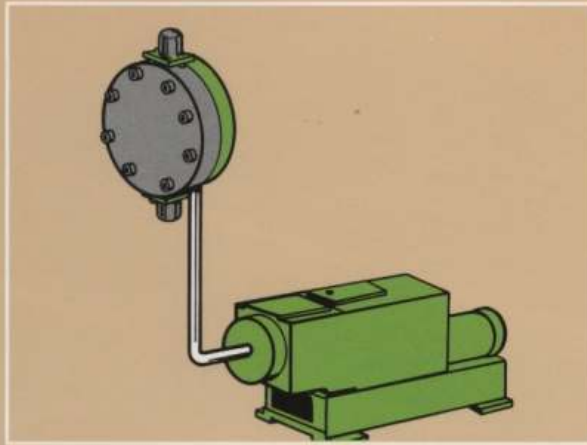

A remote head can be fitted to a PULSA Series pump for the controlled metering of very high or low temperature liquids. The remote diaphragm isolates the fluid in a controlled environment that is separate from the pumping mechanism. This design, equipped with a metal diaphragm, permits safe, isolated metering of radioactive liquids.

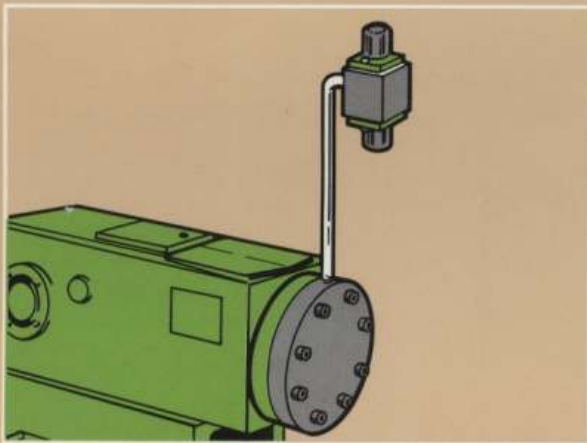

Placing the inlet and outlet check valves remote from the pump and using the product as the pulsing medium between the diaphragm and valves permits economical high or low temperature metering.

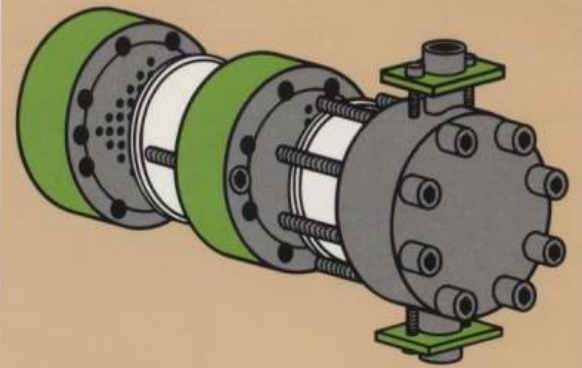

It is sometimes desirable to isolate extremely sensitive, hazardous or toxic fluids from direct contact with hydraulic fluid in the event of a diaphragm failure. Double diaphragms with a contained inert fluid between them can be used to offer optimum process protection.

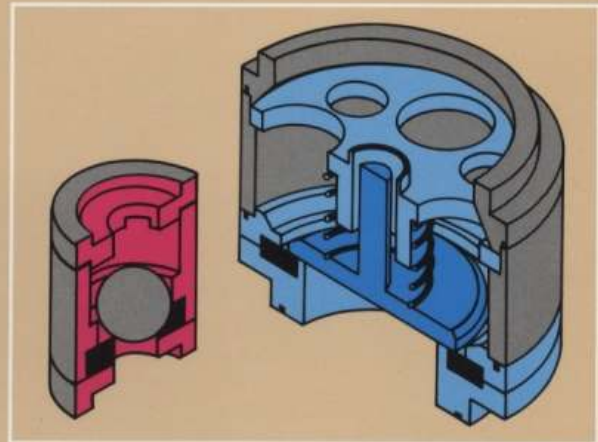

Special slurry valve assemblies are available for abrasive service. They feature high clearances and flexible elastomer seats that prevent the build up of solids. They are designed for slurries such as carbon black, diatomaceous earth, lime, etc.

# The PULSA Series Family of Diaphragm Metering Pumps

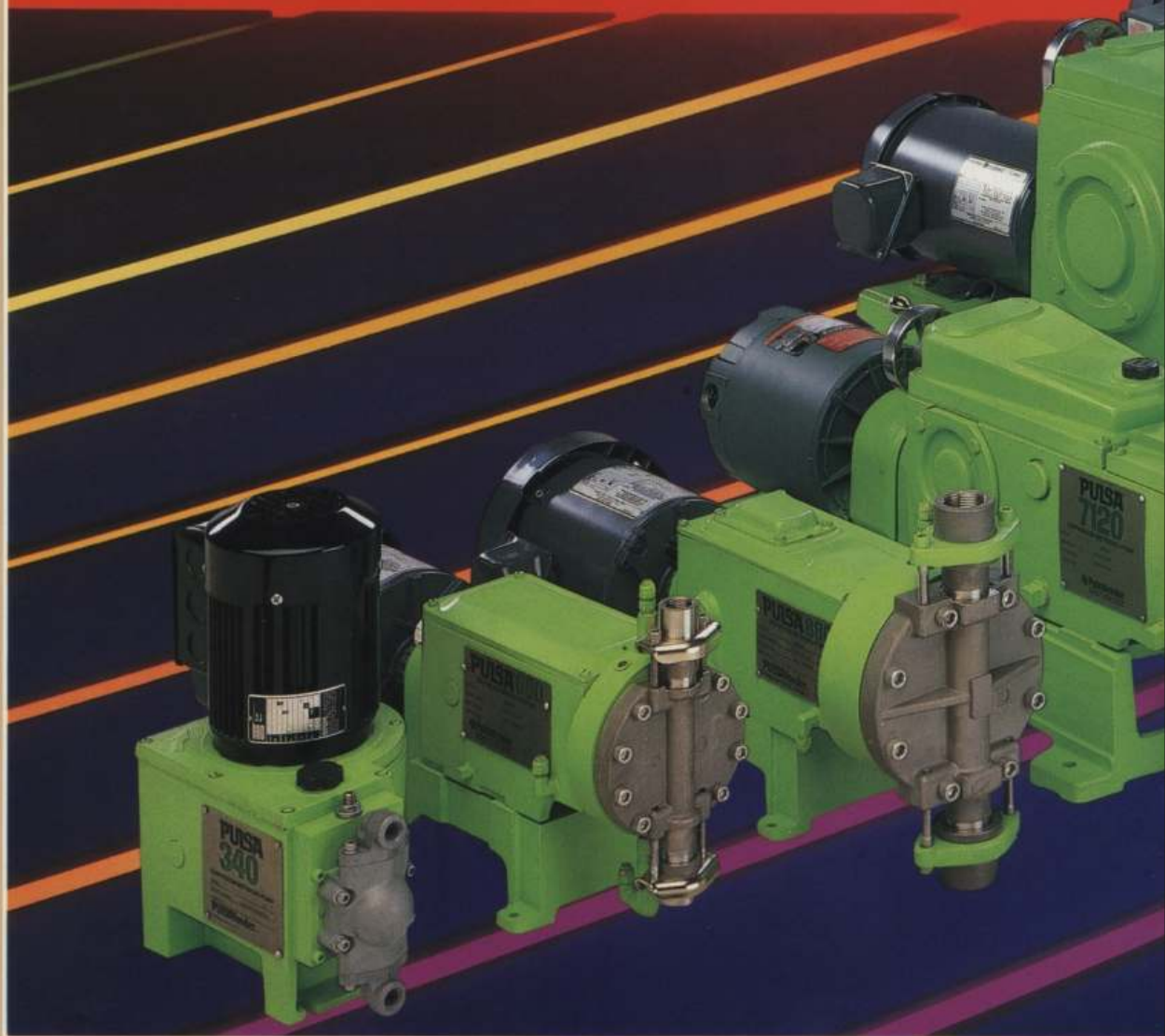

## 200

PULSA 200 pumps have 2 gear ratio selections and 2 motor speeds available for 29, 44, 58 or 88 strokes per minute. The table is based on 88 SPM.

MAXIMUM CAPACITY		MAXIMUM RATED PRESSURE	
gph	l/h	psig	kg/cm <sup>2</sup>
0.58	2.195	1000	70

This Model uses the diaphragm style similar to the HYDRACONE® and pump configuration similar to 680.

Approximate overall dimensions:

	L	W	H
inches	19.8	6.6	9
cm	50.3	16.8	22.9

## 340

PULSA 340 pumps have 2 gear ratio selections available; 88 or 175 strokes per minute. The table is based on 88 SPM.

MAXIMUM CAPACITY		MAXIMUM RATED PRESSURE	
gph	l/h	psig	kg/cm <sup>2</sup>
2.4	10.08	175	12.3
5.5	20.82	150	11
11.5*	43.5	150	11

\*175 SPM

This Model uses the HYDRACONE® style diaphragm.

Approximate overall dimensions:

	L	W	H
inches	11.7	6.1	12.5
cm	29.7	15.5	31.7

## 680

PULSA 680 pumps have 3 gear ratio selections available; 44, 88 or 148 strokes per minute. The table is based on 148 SPM.

MAXIMUM CAPACITY		MAXIMUM RATED PRESSURE	
gph	l/h	psig	kg/cm <sup>2</sup>
.39*	1.48	3000	211
1.0*	3.78	1800	127
1.76*	6.66	925	65
3.0*	11.4	600	42
6.7	25.4	400	28
10.0	37.8	300	21
13.6	51.5	235	16
17.6	66.6	185	13
22.5	85.2	150	11
27.6	104.0	130	9
32.6	123.0	100	7

\*88 spm max

This model is available with PTFE, METAL, HYDRACONE® & HYDRATUBE® style diaphragms.

Approximate overall dimensions:

	L	W	H
inches	19.8	6.6	9
cm	50.3	16.8	22.9

Capacities and stroking rates are based on 60 Hz service. To convert to 50 Hz multiply capacity and stroke rate by <sup>50</sup>/<sub>60</sub>, (0.8333).

## 880

PULSA 880 pumps have 3 gear ratio selections available; 58, 116 or 175 strokes per minute. The table is based on 175 SPM.

MAXIMUM CAPACITY		MAXIMUM RATED PRESSURE	
gph	l/h	psig	kg/cm <sup>2</sup>
4.33	16.4	1800	127
7.5	28.4	1150	81
25.0	94.6	360	25
31.0	117.0	290	20
46.0	174.0	200	14
64.0	242.0	150	11
95.0	360.0	100	7

This model is available with PTFE or HYDRATUBE® style diaphragms.

Approximate overall dimensions:

	L	W	H
inches	26	12.3	7.5
cm	66	31.2	19

Capacity vs. stroke rate is a direct relationship for all models.

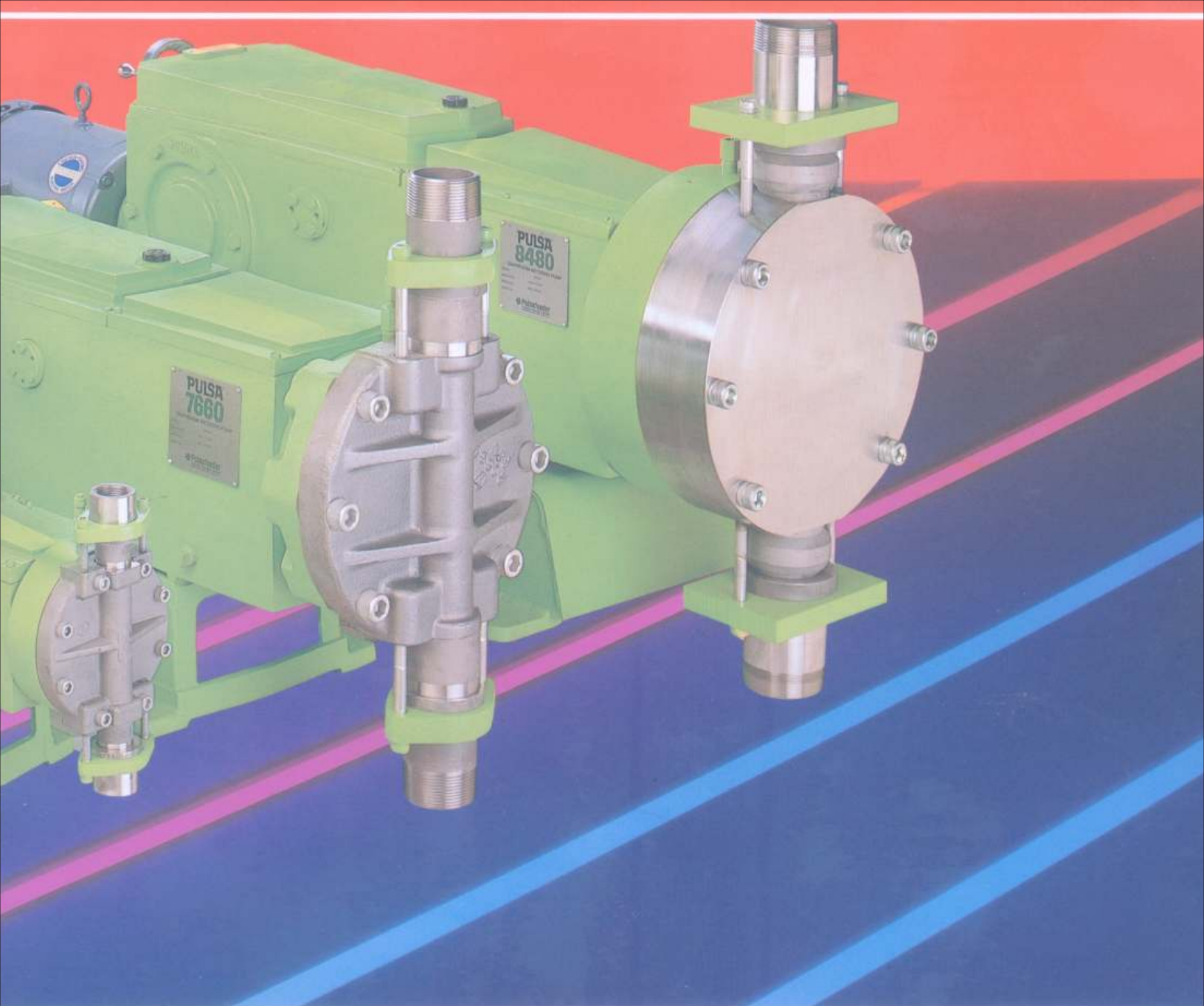

## 7120

PULSA 7120 pumps have 4 gear ratio selections available; 70, 88, 116 or 140 strokes per minute. The table is based on 140 SPM.

MAXIMUM CAPACITY		MAXIMUM RATED PRESSURE	
gph	l/h	psig	kg/cm <sup>2</sup>
2.4	9.1	3000	211
4.6	17.4	2000	141
5.7	21.6	600	42
13.7	51.8	1200	84
14.4	54.5	900	63
14.8	56.0	600	42
26.4	100.0	500	42
42.8	162.0	440	31
61.8	234.0	300	21
84.0	318.0	225	16
123.8	469.0	150	11
235.0*	889.0	100	7

\*175 spm

This model is available with PTFE, METAL & HYDRATUBE® style diaphragms.

Approximate overall dimensions:

	L	W	H
inches	31	9	12
cm	78.7	22.9	30.5

## 7440

PULSA 7440 pumps have 3 gear ratio selections and 2 motor rpms available to produce 70, 91, 114, 140 or 175 strokes per minute. The table is based on 175 SPM.

MAXIMUM CAPACITY		MAXIMUM RATED PRESSURE	
gph	l/h	psig	kg/cm <sup>2</sup>
8.0	30.3	3200	224
23.0	87.1	1600	112
45.0	170	900	63.0
73.0	276	575	40.3
107	405	400	28.0
147	556	290	20.3
220	833	200	14.0
275	1041	160	11.2
335	1268	130	9.1
440	1665	100	7

This model is available with PTFE, METAL & HYDRATUBE® style diaphragms.

Approximate overall dimensions:

	L	W	H
inches	38	9	17
cm	96.5	22.9	43.2

## 7660

PULSA 7660 pumps have 4 gear ratio selections available; 58,88, 116 or 140 strokes per minute. The table is based on 140 SPM.

MAXIMUM CAPACITY		MAXIMUM RATED PRESSURE	
gph	l/h	psig	kg/cm <sup>2</sup>
1.6*	6	5000	351
6.1	23	3000	210
11.5	43	3000	210
12.7	48	2000	140
28.8	109	2000	140
55.5	210	1100	77
56.6	214	800	56
58.3	220	500	35
94.6	358	500	35
140	530	350	24
255	965	270	18
391	1480	170	11
567	2146	120	8.4
659	2494	100	7.0
787	2978	90	6.3
988	3739	70	4.9
1250	4731	55	3.8

\*116 spm max

This model is available with PTFE, METAL & HYDRATUBE® style diaphragms.

Approximate overall dimensions:

	L	W	H
inches	48	15	18
cm	121.9	38.1	45.7

## 8480

PULSA 8480 pumps have 3 gear ratio selections available; 60, 85 or 113 strokes per minute. The table is based on 113 SPM.

MAXIMUM CAPACITY		MAXIMUM RATED PRESSURE	
gph	l/h	psig	kg/cm <sup>2</sup>
7.1	26	5000	351
12.8	48	3200	224
31.7	120	3200	224
60.0	227	1800	126
100.6	380	1200	84
151.3	572	800	56
280	1059	450	31
445	1684	300	21
648	2452	200	14
761	2880	175	12
1164	4405	120	8.4
1445	5469	90	6.3

This model is available with PTFE, METAL & HYDRATUBE® style diaphragms.

Approximate overall dimensions:

	L	W	H
inches	61	18	21
cm	154.9	45.7	53.3

## **PULSA Series Pumps Are Available With Electric And Pneumatic Controls**



- Output can be varied from 0 to 100% through electric or pneumatic signals that control the stroke length.
- This unique control houses the entire circuit board and all components in a NEMA 4 enclosure on the pump. Explosion proof is also available.
- Remote signal cutout switch with manual micrometer override is a standard feature.
- The advanced closed loop control system utilizes AC synchronous motor technologies for precision adjustment.
- State-of-the-art componentry has plug-in capability for analog, and pneumatic process signals, ratio control, meter drive.

### **PULSAmatic® For Automatic Pump Control**

PULSAmatic was designed to provide continuous and automatic flow-rate control for PULSA 7120, 7440, 7660 and 8480 series pumps.

- Employs advanced solid-state electronics.
- Power consumption is only 23 watts max. because the unique design uses the power from the pump mechanism to adjust settings.
- Pump output is displayed by a mechanical digital stroke length indicator (calibrated 0-100%).
- A mechanical handwheel override gives manual control of the pump whenever necessary.
- A weatherproof NEMA 4 enclosure provides maximum protection, even in hostile environments. Explosion proof is also available.
- All PULSAmatic control circuitry is self contained at the pump. There are no cumbersome wall cabinets to mount.
- Versatility is provided through a wide selection of control options and enclosures, including the ability to interface with a microprocessor for pump control.



### **Pneumatic Controls**

Pneumatic controls are available for the PULSA Series for 0-100% pump output from a pneumatic signal. The 7120, 7440, 7660 and 8480 design features a fully enclosed operating mechanism. The 200, 680 and 880 design have optional 0-100% ratio capability.

- 3-15 psi instrument signal standard. Other ranges optional including split ranging.
- Direct acting standard. Reverse acting optional.
- Designs for natural gas operation are also available.



### **Unique Electric Stroke Length Control For PULSA Models 880, 680, and 200**

Here is an optional attachment that's made to order for PULSA 880, 680, and 200 installations that require automatic process control. It's also the answer for required remote control of the pump capacity.

## Add Extra Capabilities To PULSA Series Pumps With These Accessories



### ChemAlarm®

Available on HYDRATUBES® and other double diaphragm pumps, ChemAlarm measures conductivity of the intermediate fluid. Any change due to introduction of the process fluid is immediately detected through a control relay to activate an alarm or shut off the pump.

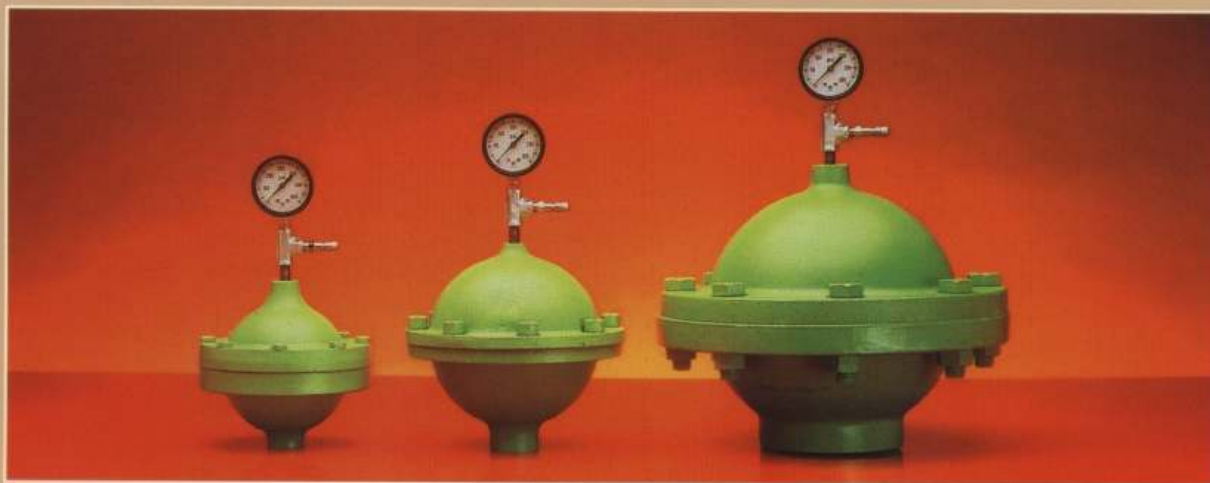

### PULSAtrol® Pulsation Dampeners

It is good practice to install pulsation dampeners in piping to and from a reciprocating pump. PULSAtrol pulsation dampeners are designed for corrosive application and feature a diaphragm barrier to isolate the air cushion from fluids in the piping system. This eliminates variations in effectiveness and recharging due to air cushion absorption into the process fluid. Single diaphragm models are available with 316SS, #20SS and PVDF coated bodies. Double diaphragm models are available with PVC and glass filled PTFE where metals are not acceptable. Diaphragms are available in DuPont's Viton, Hypalon and Nardel elastomers. Sizes to 230 in.<sup>3</sup> (3.77 liter). Pressures to 500psi (35kg/cm<sup>2</sup>).

#### PULSAtrol Benefits:

- Reduces hydraulic hammer in pipe lines.
- Creates more favorable net positive suction head conditions on inlet side of metering pumps.
- Allows use of smaller piping, reducing system costs.
- Helps to protect piping and joints from pressure surges.
- Changes pulsating flow to near linear in combination with a back pressure valve.



### Diaphragm Back Pressure Valve

Where inlet pressure exceeds discharge pressure, or where forces in the intermittent flow cause "siphoning", diaphragm back pressure valves are used to create the necessary differential pressure. Constant back pressure is maintained without chatter or cycling. Serviceable in place. Adjustable from 15 to 50 psi.

## We Wrote The Book On Metering Pumps

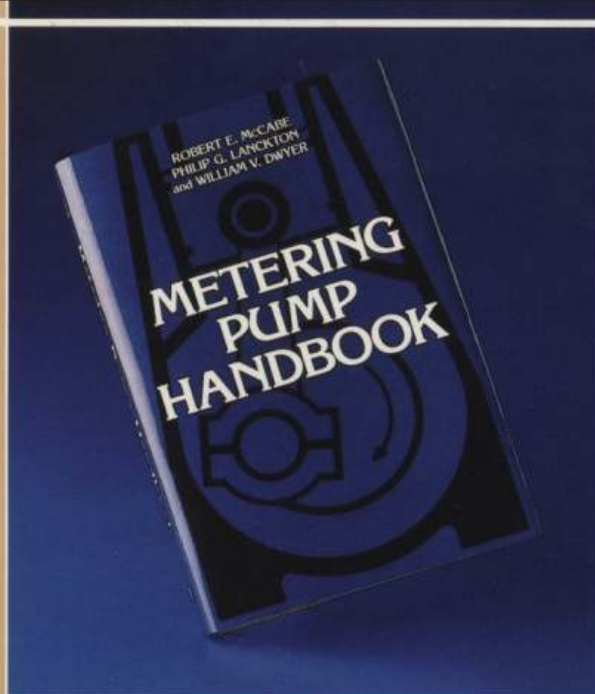

### Here's The Ideal Reference Book For Anyone Who Deals With Metering Pumps

- Everything you need to know about metering pumps . . . 280 pages of helpful information
- Well organized and easy to read
- Loaded with useful diagrams and charts
- Write or call Pulsafeeder or contact your PULSA Series sales representative.

## PULSAFEEDER

A Unit of IDEX Corporation

Manufacturers of Quality Pumps,  
Controls and Systems.

2883 Brighton-Henrietta Town Line Road  
Rochester, NY 14623  
716-292-8000

<http://www.pulsa.com>

Fax: 716-424-5619

Pulsafeeder Sales Offices are located in most major cities.

**IDEX**  
IDEX CORPORATION



\*PULSA, \*PULSA Series, \*HYDRATUBE, \*HYDRACONE, \*PULSAmatic, \*PULSAtrol,  
and \*ChemAlarm are registered trademarks.  
• \*DYNALLOY registered trademark Muller Brass Co.  
• \*Teflon registered trademark DuPont