

# ECO Gearchem<sup>®</sup>

Alloy gear pumps offering versatility in chemical services.

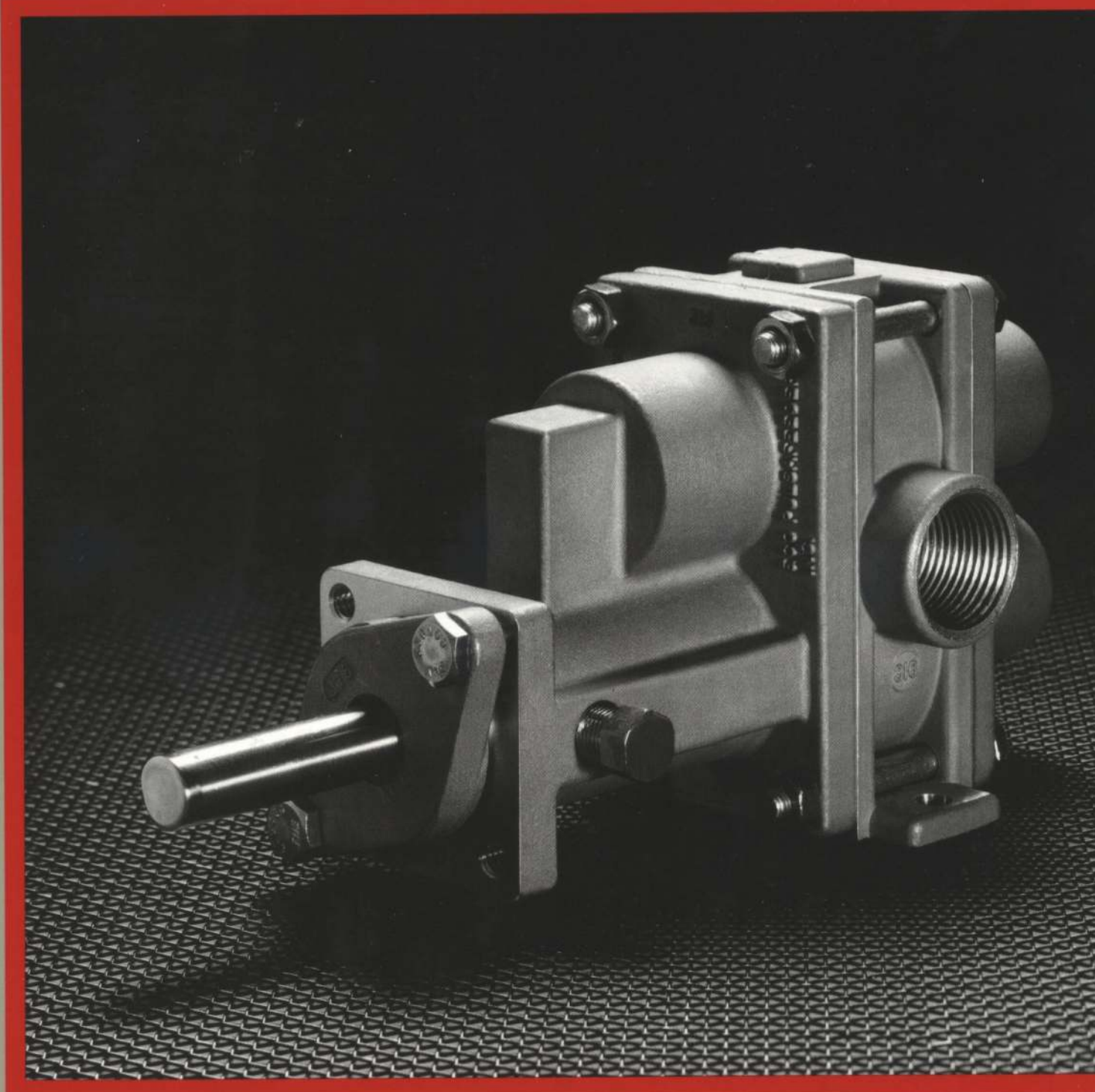

**PULSAFEEDER**  
A Unit of IDEX Corporation

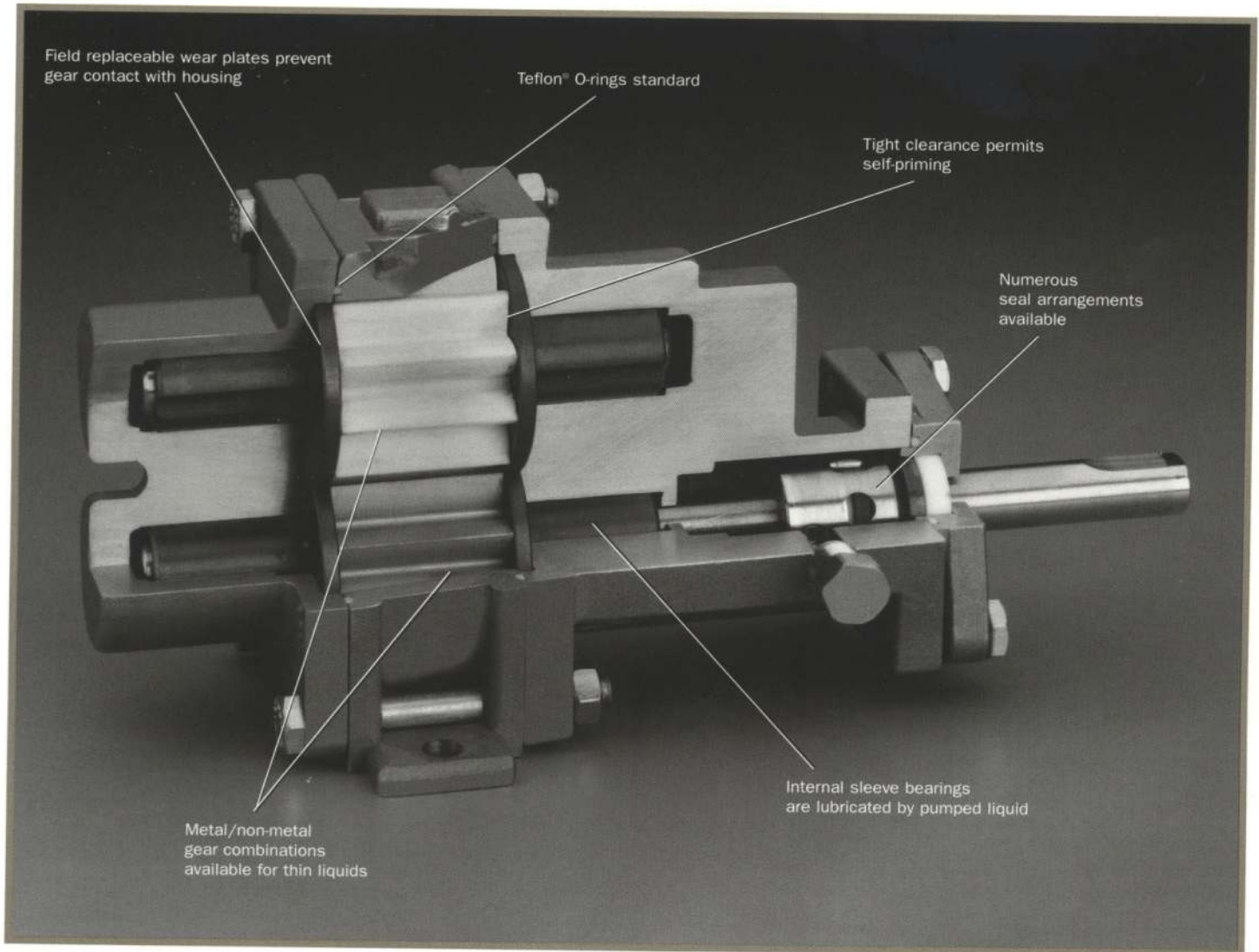

ECO Gearchem pumps offers the reliability you need to safely handle clear lubricating and non-lubricating liquids. Extensive material availability provides versatility for pumping low or high viscosity fluids over a broad range of temperatures, pressures, and corrosive services. Typical applications for these self-priming, external-spur gear pumps include chemical transfer, cyclic operations and continuous production systems—both open-end and closed loop. They are also well suited for pilot plants, vacuum systems and metering applications.

At the heart of each ECO Gearchem pump are two tightly toleranced, machine-generated spur gears

consisting of a drive and an idler gear. Self-priming capability is accomplished by our closely toleranced gears which evacuate air from the suction piping. Gearchem pumps provide linear, pulsation-free flows. And the pumps are bidirectional. This lets you easily change flow direction.

We offer eight models with a maximum capacity of 60 GPM (13.6 m<sup>3</sup>/h). Maximum differential pressure extends to 200 psi (13.8 bar). ECO pumps are designed for temperatures ranging from - 100°F to +450°F (-73°C to +232°C). Gearchem pumps are ideal for vacuum applications where system pressures are as low as .1mm Hg abs.

# ECO Gearchem®

# Extensive Material Availability To Satisfy Your Pumping Needs.

Pump housing components and drive and idler gear shafts are available in two types of austenitic stainless steels—316 and Alloy 20—and high-nickel Alloy C. All housings are investment-cast and precision machined for high quality and durability.

## Gears.

A broad selection of metallic and non-metallic gears are available to meet a wide variety of process conditions. This includes non-sparking, gall resistant Alloy C. Alloy 20 stainless steel is also available.

Where the conditions do not allow metal-to-metal contact, glass-filled Teflon, carbon graphite and PEEK (polyetheretherketone) can also be used as gear materials. In conjunction with a metallic drive gear, these materials allow extended life at full-speed operation even with fluids with viscosities less than 1 cps.

## Wearplates.

Wearplates are used on ECO Gearchem pumps to permit easy restoration of a pump to "like-new" performance.

Carbon graphite wearplates are used most often since they are suitable for all pump speeds over the full range of viscosities and temperatures. Additional materials include glass-filled Teflon and ceramic which are used in certain applications such as those where exposure to strong oxidizers makes carbon graphite unsatisfactory.

## Bearings.

Bearings used in ECO Gearchem pumps are of the internal sleeve type and are cooled and lubricated by the pumped fluid. This eliminates the risk of contamination from external lubricating materials. Carbon graphite and glass-filled Teflon are offered because of their proven durability and inherent self-lubricating properties.

## Mechanical Seals.

Our pump seals prevent or minimize product leakage and ingress of air to the process stream. Selection of the seal arrangement—probably the most important step in pump specification—depends upon suction pressure, discharge pressure, viscosity and other fluid characteristics and type of service.



ECO Gearchem pumps allow for quick and easy conversion in the field from one type of seal to another, if required, without special tools or training.

Three types of seal and packing arrangements are available for ECO Gearchem pumps: (1) internal mechanical seals (single or double); (2) external mechanical seals (for pressure or vacuum service); and (3) mechanical packed boxes (standard and lantern ring).

Mechanical seals on ECO Gearchem pumps are of both wedge and bellows design to cover the widest range of services. Primary sealing is accomplished by the lapped surface of the primary seal ring rotating against the lapped mating face of the stationary seat. Positive sealing along the shaft is obtained by a Teflon sealing wedge or viton elastomer bellows. And Teflon O-rings, Viton O-rings or gaskets seal the stationary seat against the seal housing.

The single internal mechanical seal is suitable for all recommended pump operating pressures and temperatures to 250°F (121°C). For fluids that tend to crystallize or precipitate, or for vacuum or high temperature applications, a double mechanical seal is often used.

An external mechanical seal is mounted outside the pump housing. This arrangement permits easy adjustment and inspection of the seal faces. The optional vacuum seal provides a vacuum seal for operating pressures as low as .1mm Hg abs.

The mechanical packed box designs use braided Teflon or Grafoil® rings to control leakage along the shaft.

See pg. 6 for a listing of all available seal arrangements and materials.

## Options.

Under certain process conditions, special options are required to insure that the pump operates satisfactorily. For more information call your local ECO distributor.



## Gear Pump Accessories.

### Pressure Relief and Back Pressure Diaphragm Valves.

ECO diaphragm relief valves and back pressure valves have been developed to provide long life and reliable service in systems handling corrosive fluids. The valves are supplied with all wetted parts of either 316 stainless steel, Alloy 20 or Alloy C.

ECO diaphragm relief valves are designed to relieve potentially dangerous overpressures in systems handling corrosive fluids.

ECO back pressure valves provide a preset pressure in the discharge system of pumps handling corrosive fluids.

Although developed specifically for use with ECO Gearchem pumps, the valves are widely used in a variety of general liquid service applications with other types of pumping equipment.



### Bolt-on Jacket.

Bolt-on jackets are available for ECO Gearchem pumps to enable the user to maintain close control of pumping temperatures. The jackets are particularly useful where fluids tend to thicken, solidify or precipitate, when temperatures decrease, or where liquids with high vapor pressures need to be kept cool to prevent vapor locking.

The jackets are designed to conform closely to pump contours to transfer heat evenly. The heating or cooling medium may be steam, a heat transfer fluid or coolant.

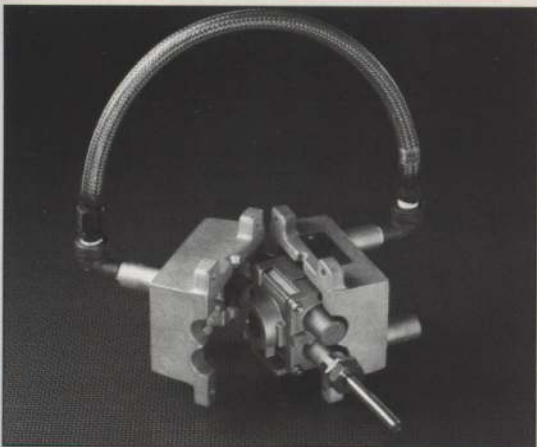

### Base-mounted Units.

ECO Gearchem pumps can be supplied as complete systems for simple installation by the customer.

All Gearchem pumps can be mounted on formed bases of heavy-gauge carbon or stainless steel. Various drive options are available for driving the pump including fixed-speed electric motors, variable-speed drives (electrical and mechanical) and air motors. Flexible couplings are supplied with an OSHA-approved guard.

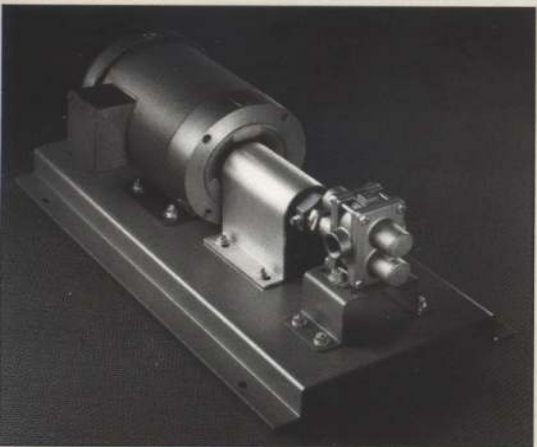

### Close-coupled Units.

Close-coupled ECO Gearchem pumps provide a compact alternative for limited space requirements. This one piece design affords simple installation. The close-coupled pumps provide an inherent safety for rotating components.

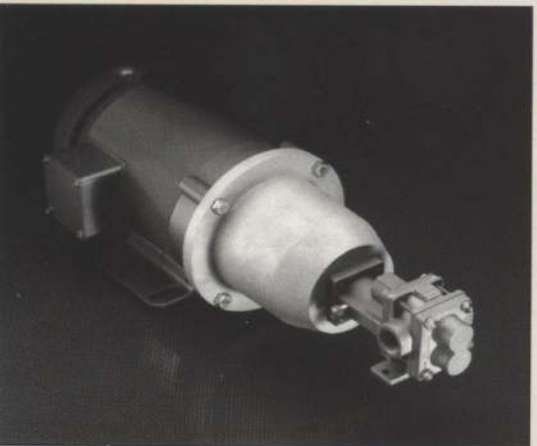

# Specifications

General Specifications Model Designation	G2/GA/GC	G4/GA/GC	G6/GA/GC	G8/GA/GC	GH6	GH8	GA12	GA16
Port size and type	1/4" NPT or BSPT	1/2" NPT or BSPT	3/4" NPT or BSPT	1" NPT or BSPT	3/4" NPT or BSPT	1" NPT or BSPT	1 1/2" FNPT or BSPT: 150# ANSI RF flange	2" 150# ANSI RF flange
Port locations	Side inlet & outlet	Side inlet & outlet	Side inlet & outlet	Side inlet & outlet	Side inlet & outlet	Side inlet & outlet	Side inlet & outlet	Side inlet & outlet
Direction of rotation	Bidirectional	Bidirectional	Bidirectional	Bidirectional	Bidirectional	Bidirectional	Bidirectional	Bidirectional
Theoretical displacement	.108 gal/100 rev (4.10 cc/rev)	.189 gal/100 rev (7.16 cc/rev)	.684 gal/100 rev (25.89 cc/rev)	1.368 gal/100 rev (51.79 cc/rev)	.684 gal/100 rev (25.89 cc/rev)	1.368 gal/100 rev (51.79 cc/rev)	2.792 gal/100 rev (105.7 cc/rev)	5.584 gal/100 rev (211.4 cc/rev)
Drive shaft diameter	3/8"	3/8"	1/2"	1/2"	3/4"	3/4"	1"	1 1/4"
Maximum differential pressure	100 psi (700 kPa)	100 psi (700 kPa)	100 psi (700 kPa)	50 psi (350 kPa)	200 psi (1380 kPa)	100 psi (700 kPa)	150 psi <sup>1</sup> (1050 kPa)	100 psi (700 kPa)
Minimum system pressure	0.1mm Hg (abs)	0.1mm Hg (abs)	0.1mm Hg (abs)	0.1mm Hg (abs)	0.1mm Hg (abs)	0.1mm Hg (abs)	0.1mm Hg (abs)	0.1mm Hg (abs)
Maximum system pressure	200 psi	200 psi	150 psi	150 psi	210 psi	200 psi	200 psi	200 psi
Maximum speed	1725 rpm	1725 rpm	1725 rpm	1725 rpm	1725 rpm	1725 rpm	1150 rpm	1150 rpm
Capacity at maximum speed, 0 psi <sup>2</sup>	1.5 gpm (.34 m <sup>3</sup> /hr)	3 gpm (.68 m <sup>3</sup> /hr)	10 gpm (2.27 m <sup>3</sup> /hr)	22 gpm (5.0 m <sup>3</sup> /hr)	10 gpm (2.27 m <sup>3</sup> /hr)	22 gpm (5.0 m <sup>3</sup> /hr)	28 gpm (6.3 m <sup>3</sup> /hr)	60 gpm (13.6 m <sup>3</sup> /hr)
Maximum viscosity <sup>3</sup>	100,000 cP	100,000 cP	100,000 cP	100,000 cP	100,000 cP	100,000 cP	100,000 cP	100,000 cP
Minimum viscosity	None	None	None	None	None	None	None	None
Maximum fluid temperature	450° F (232°C)	450° F (232°C)	450° F (232°C)	450° F (232°C)	450° F (232°C)	450° F (232°C)	450° F (232°C)	450° F (232°C)
Minimum fluid temperature	-100°F (-73°C)	-100°F (-73°C)	-100°F (-73°C)	-100°F (-73°C)	-100°F (-73°C)	-100°F (-73°C)	-100°F (-73°C)	-100°F (-73°C)
Fluid pH range	0-14	0-14	0-14	0-14	0-14	0-14	0-14	0-14
Bearing type	Internal sleeve	Internal sleeve	Internal sleeve	Internal sleeve	Internal sleeve	Internal sleeve	Internal sleeve	Internal sleeve
Bearing lubrication	By pumped fluid	By pumped fluid	By pumped fluid	By pumped fluid	By pumped fluid	By pumped fluid	By pumped fluid	By pumped fluid
Packing arrangements	Standard or lantern ring box	Standard or lantern ring box	Standard or lantern ring box	Standard or lantern ring box	Lantern ring box	Lantern ring box	Lantern ring box	Lantern ring box
Mechanical seals	Single internal, double or external	Single internal, double or external	Single internal, double or external	Single internal, double or external	Single internal or double	Single internal or double	Single internal or double	Single internal or double
Approximate weight, pump only	4.2 lbs (1.9 kg)	4.2 lbs (1.9 kg)	7 lbs (3.2 kg)	10 lbs (4.5 kg)	11.2 lbs (5.1 kg)	14 lbs (6.3 kg)	39 lbs (17.6 kg)	80 lbs (36.3 kg)

<sup>1</sup> Consult factory for approved application above 100 psi

<sup>2</sup> At nominal viscosity

<sup>3</sup> At reduced speeds. (Higher viscosities possible with further speed reduction.)

## Dimensions

MODELS G2 THROUGH GH8

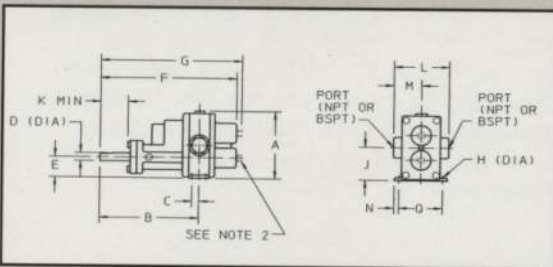

MODEL GA12 and GA16

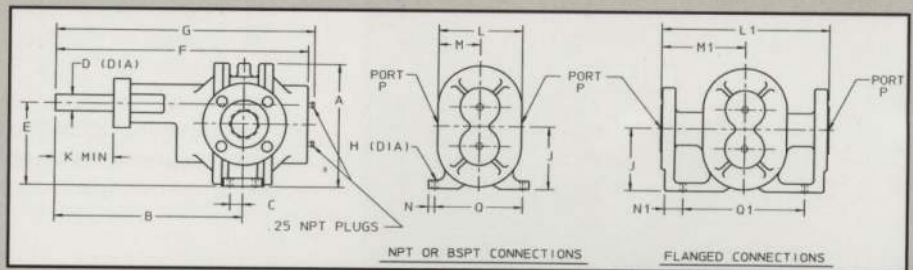

MODEL	PORT	A	B	C	D	E	F	G	H	J	K MIN	L	M	N	Q
GA2	.25	2.88	5.70	-	.38	.88	7.32	7.63	.29	1.38	1.07	2.88	1.44	.25	3.00
GA4	.50	2.88	5.70	-	.38	.88	7.32	7.63	.29	1.38	1.07	2.88	1.44	.25	3.00
GA6	.75	4.09	5.98	-	.50	1.25	8.19	8.50	.29	2.00	.94	3.32	1.66	.28	2.62
GA8	1.00	4.19	7.48	.62	.50	1.38	10.32	10.63	.28	2.12	1.81	4.00	2.00	.28	2.62
GH6	.75	4.09	7.85	-	.75	1.25	10.66	10.97	.29	2.00	1.22	3.32	1.66	.28	2.62
GH8	1.00	4.19	8.47	.62	.75	1.38	11.91	12.29	.28	2.12	1.22	4.00	2.00	.28	2.62

PORT SIZES	
NPT OR BSPT	150 LB RF FLG
P	P

MODEL	NPT OR BSPT CONN												FLANGED CONN							
	P	P	A	B	C	D	E	F	G	H	J	K MIN	L	M	N	Q	L1	M1	N1	Q1
GA12	1.50	1.50	7.50	11.25	.75	1.00	5.00	15.12	15.50	.34	3.81	3.25	5.00	2.50	.38	5.25	10.00	5.00	1.09	7.25
GA16	-	2.00	8.75	12.25	1.75	1.00	6.25	17.12	17.50	.53	5.06	3.25	-	-	-	-	10.50	5.25	1.44	6.50

Notes:

1) Suction and discharge ports are dependent upon rotation.

2) Bearing flush plugs (.12 NPT) are optional for GA2-GH8.

3) All dimensions are in inches

# How To Select The Right Pump.

Position No.  
Model No.

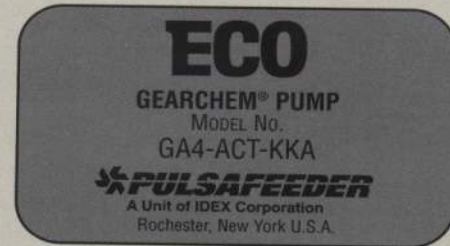
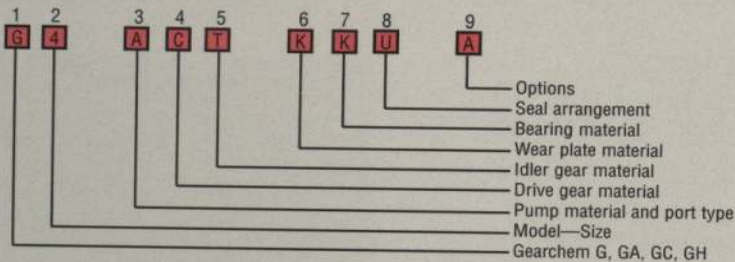

All ECO pump identification plates include the basic model number. These numbers fully describe the pump and seal specifications necessary for the future identification of your pump, and the replacement of parts or equipment, as needed.

Look at the sample model number (above) to see what information these numbers contain.

Note: Be sure to provide complete nameplate data when you order spare parts or replacement pumps.

## Pump identification number selection guide

Position 1 Gearchem External Spur Gear Pump									
G = Original Version, Foot Mounted Only	2,4,6,8								
GA = Mechanical Seal, Foot Mounted Only	2,4,6,8,12,16								
GC = Mechanical Seal, C-Face Motor Mounting Assembly	2,4,6,8								
GH = Higher Pressure Model, Foot Mounted Only	6,8								
Position 2 Pump Size									
Port Size	2	4	6	8	*6	*8	12	16	
Capacity (GPM MAX)	.25"	.50"	.75"	1.00"	.75"	1.00"	1.50"	2.00"	
Differential Pres (PSI MAX)	100	100	100	50	200	100	100	100	
Position 3 Available Pump Metallurgies and Type Port Connection									
A = 316SS FNPT	X	X	X	X	X	X	X	X	
C = Alloy C FNPT	X	X	X	X	X	X	X	X	
D = Alloy 20 FNPT	X	X	X	X	X	X	X	X	
K = 316SS FBSPT	X	X	X	X	X	X	X	X	
M = Alloy C FBSPT	X	X	X	X	X	X	X	X	
N = Alloy 20 FBSPT	X	X	X	X	X	X	X	X	
U = 316SS Flanged									X
V = Alloy C Flanged									X
W = Alloy 20 Flanged									X
Position 4 Drive Gear Material									
C = Alloy C	X	X	X	X	X	X	X	X	X
D = Alloy 20	X	X	X	X	X	X	X	X	X
T = TFE (Glass-filled) (1)	X	X	X	X	X	X	X	X	X
E = PEEK (1)	X	X	X	X	X	X	X	X	X
Position 5 Idler Gear Material									
C = Alloy C (2)	X	X	X	X	X	X	X	X	X
D = Alloy 20 (2)	X	X	X	X	X	X	X	X	X
K = Carbon	X	X	X	X		X	X	X	X
T = TFE (Glass-filled)	X	X	X	X		X	X	X	X
E = PEEK	X	X	X	X		X	X	X	X
Position 6 Wear Plate Material									
K = Carbon	X	X	X	X	X	X	X	X	X
T = TFE (Glass-filled)	X	X	X	X	X	X	X	X	X
Z = Ceramic (3)	X	X	X	X	X	X	X	X	X
E = PEEK	X	X	X	X	X	X	X	X	X
Position 7 Shaft and Bearing Material									
K = Standard Carbon	X	X	X	X	X	X	X	X	X
T = TFE (Glass-filled)	X	X	X	X	X	X	X	X	X
L = Extended Life Carbon	X	X	X	X	X	X	X	X	X
C = Extended Life Carbon 'CW' Shafts	X	X	X	X	X	X	X	X	X
4 = Standard Carbon(Slotted)									X
Position 8 Seal Arrangement									
	G 2-4	GA/GC 2-4	G 6-8	GA/GC 6-8	GH *6	GH *8	GH *12	GH *16	GA 12-16
<b>PACKING</b>									
B = TFE Rings	X		X						
G = Grafoil® Rings	X		X						
J = Viton Lip Seal H-C Spring(4)	X		X						
N = TFE Rings /Lantern	X		X						
R = Grafoil® / Lantern	X		X		X	X			X
<b>MECHANICAL SEALS (5)</b>									
<b>BELLOWS</b>									
A = Single Seal: Carbon Rotary / Viton Ceramic Seat / Viton		X		X					
C = Double Seal: Carbon Rotary / Viton Ceramic Seat / Viton (6)		X		X					
P = Single Seal: Siliconized Rotary / EPR Siliconized CBD Seat / TFE		X		X					
<b>WEDGE</b>									
E = Double Seal: Carbon Rotary / TFE Silicon CBD Seat / TFE (6)		X		X	X	X			X
Q = Single Seal: Teflon Rotary / TFE Silicon CBD Seat / TFE		X		X	X	X			
U = Single Seal: Carbon Rotary / TFE Silicon CBD Seat / TFE		X		X	X	X			X
V = External Seal: Carbon Rotary / TFE Metallic Seat / TFE	X		X						
W = External Seal: Carbon Rotary / TFE Silicon CBD Seat / TFE			X						
Z = External Seal: Vacuum Carbon Rotary / TFE Metallic Seat / TFE	X		X						
24 = Single Seal: Carbon Rotary / TFE Metallic Seat / TFE									X
44 = Double Seal: Carbon Rotary / TFE Metallic Seat / TFE (6)									X
Position 9 Options									
Consult you local distributor for options to meet your special requirements									

Notes:

- Maximum differential pressure allowed for plastic/plastic gears is 50PSIG.
- Pumps with metallic drive and idler gears require minimum viscosity of 100 cps and are limited to 1440 RPM maximum speed for G2-GH8 pumps and 1150 RPM for GA12-16 pumps.
- Ceramic wear plates with metallic gears require minimum viscosity of 100 cps.
- Viton U-cup lip seals are limited to 25 psi.
- Not all mechanical seals available in all metallurgies.
- Double mechanical seals must be pressurized with seal fluid 15 to 20 PSIG above the pump discharge pressure.

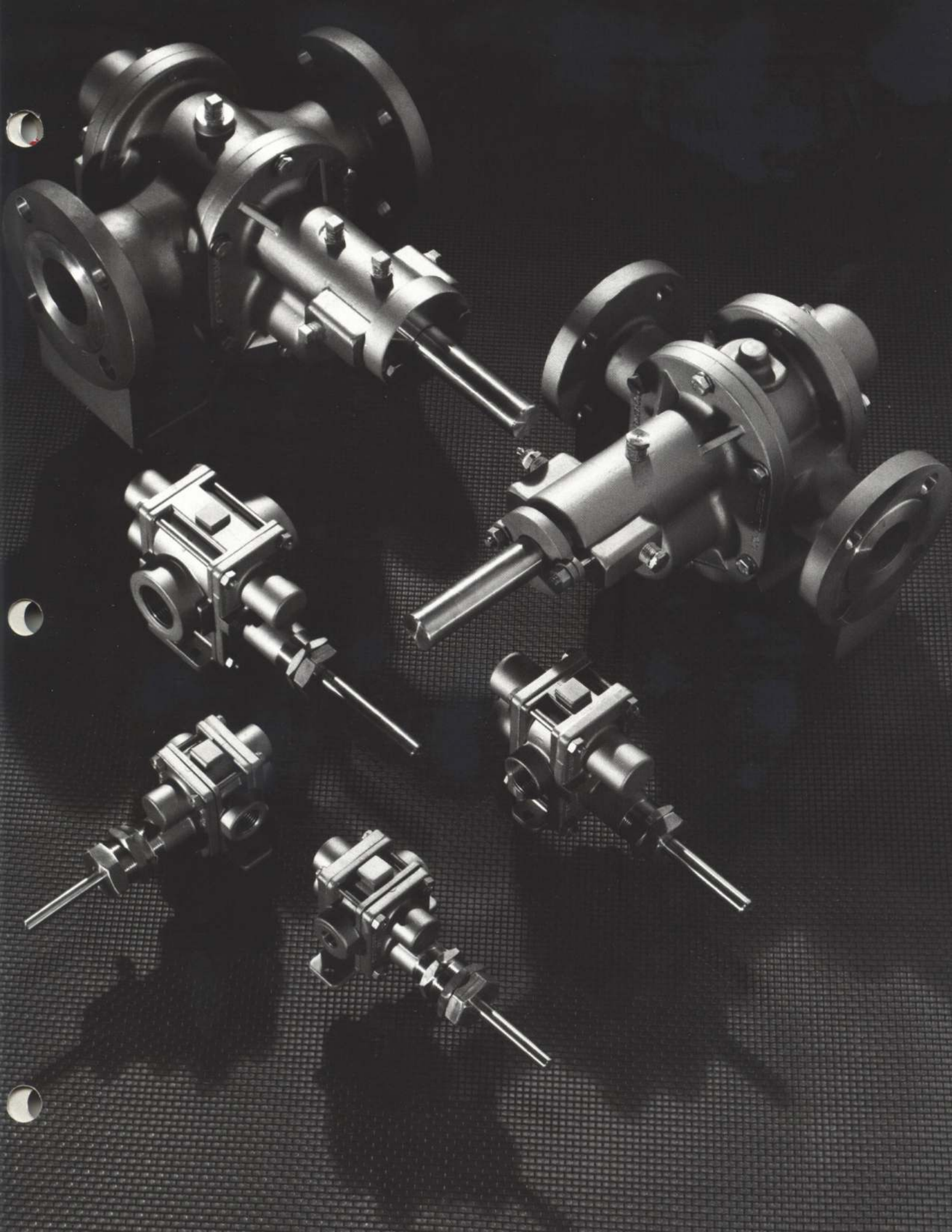

# G2

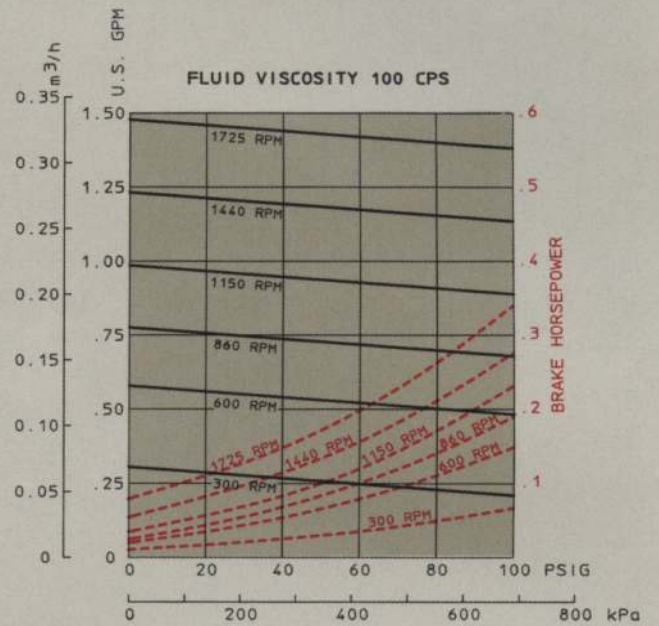
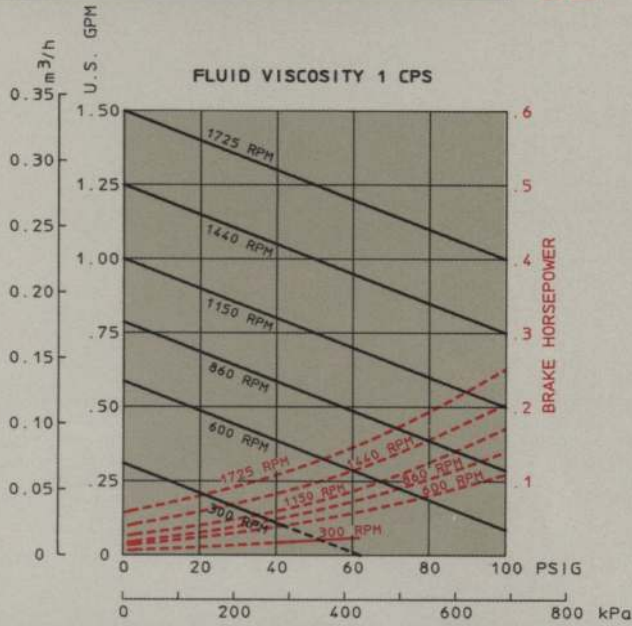

# G4

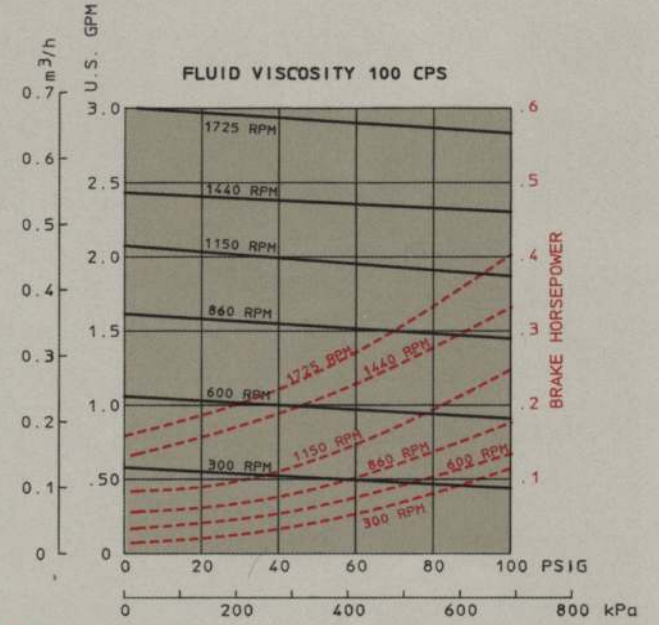
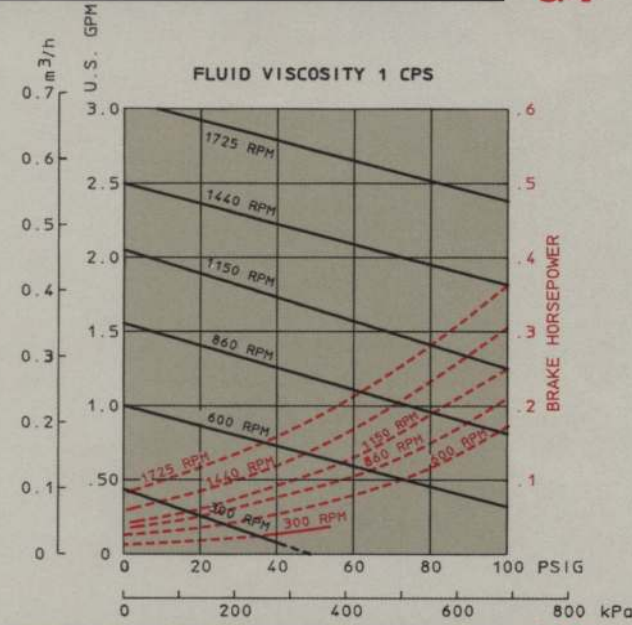

# G6 and GH6

Note: maximum differential pressure for G6 is 100 psi (700 kPa)

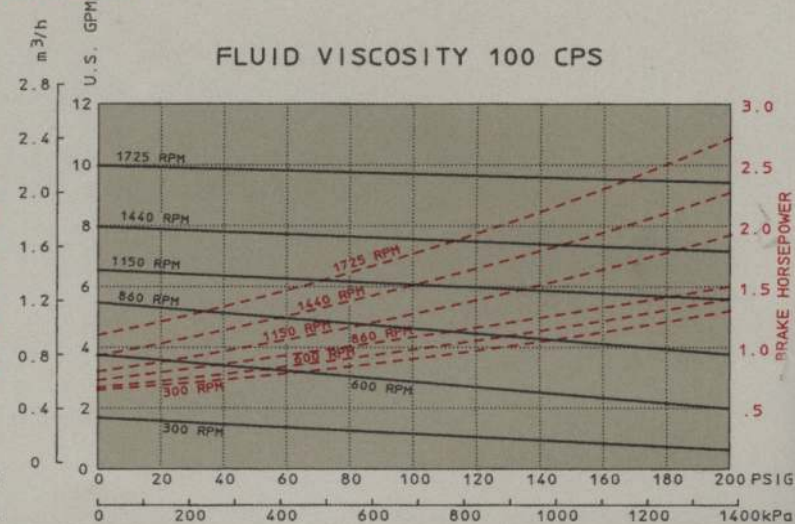
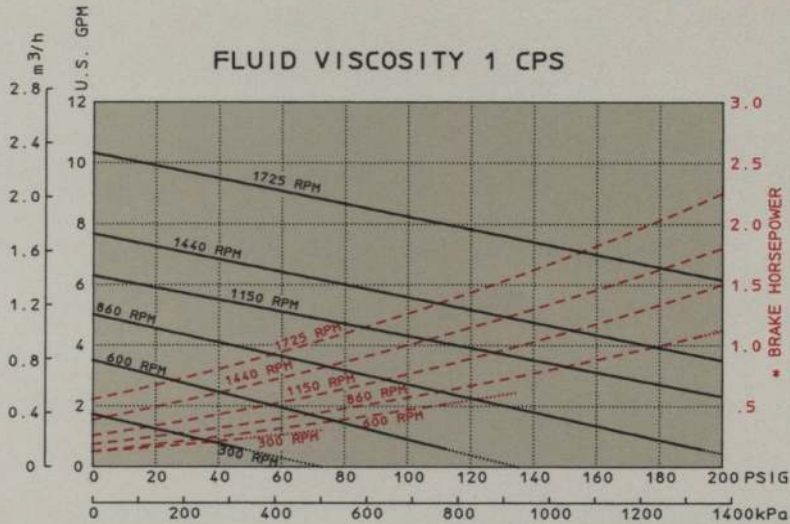

# G8 and GH8

Note: maximum differential pressure for G8 is 50 psi (360 kPa)

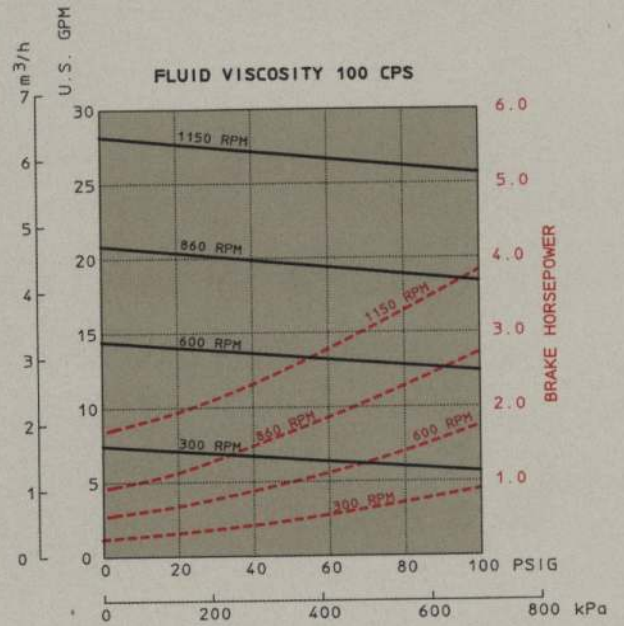
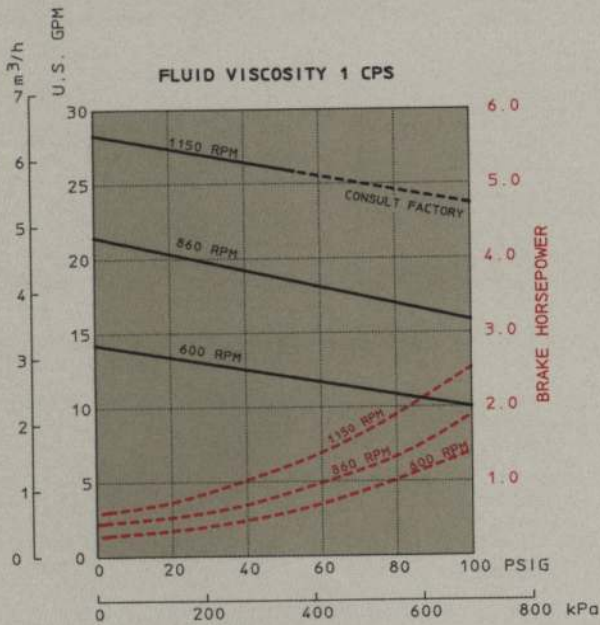
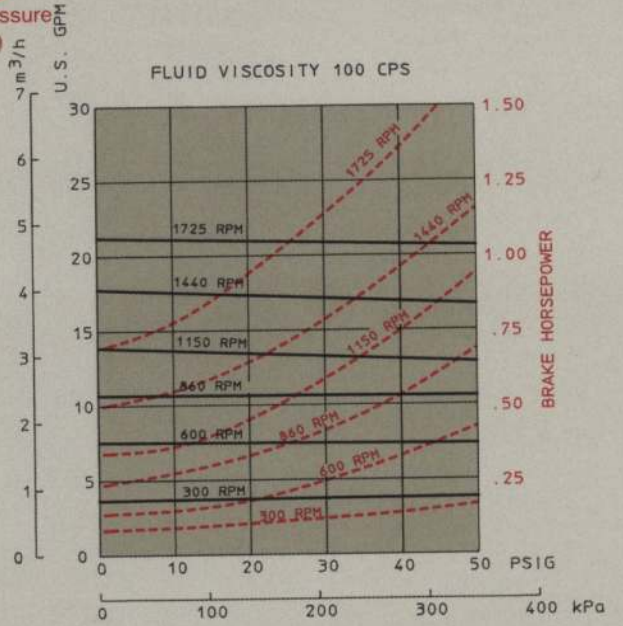
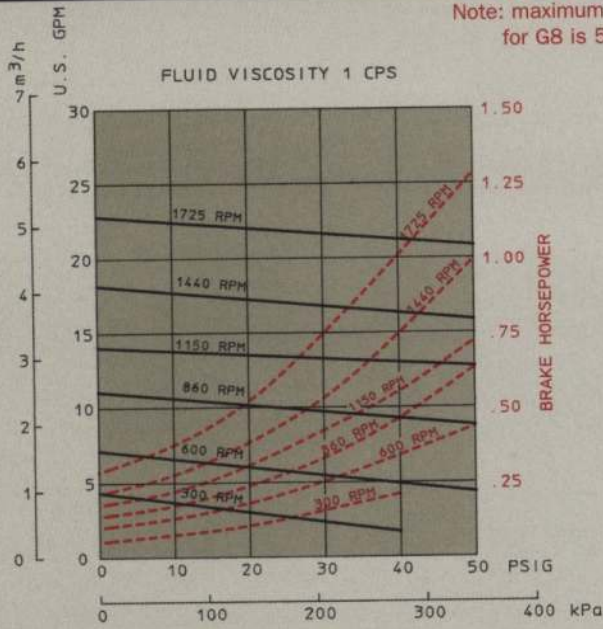

# GA16

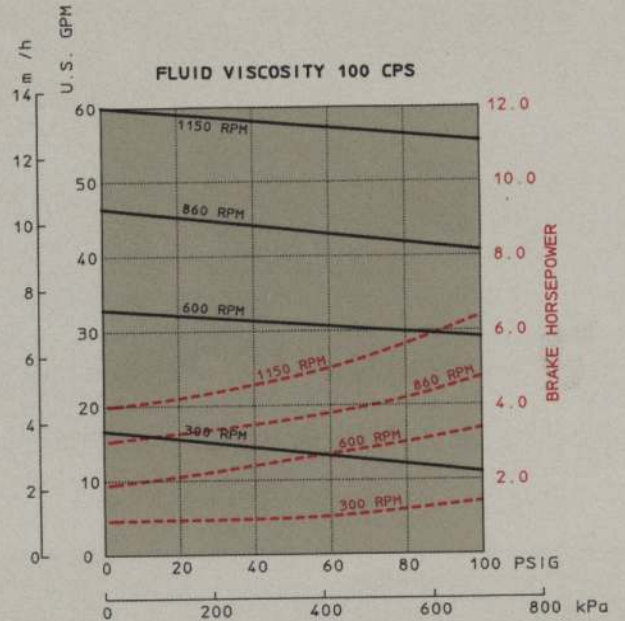
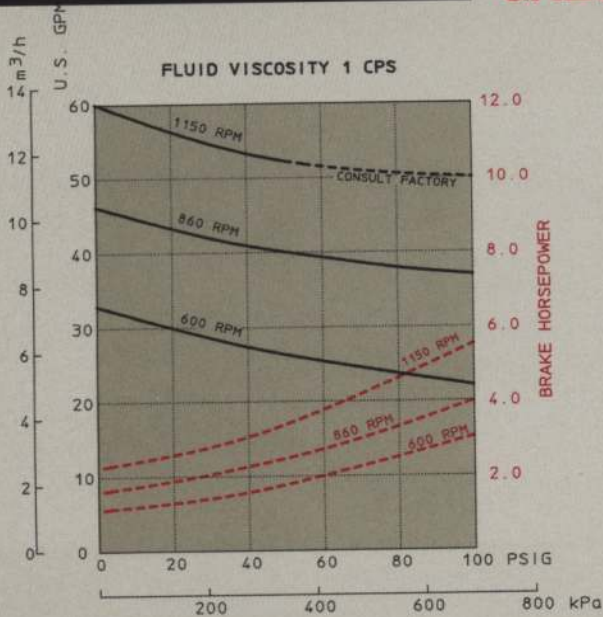



To guard against unnecessary down time, we recommend that you purchase an ECO Keep-On Pumping Kit or KOPkit, with the purchase of a pump. These overhaul kits contain those recommended spare parts which will most likely require normal maintenance. Each KOPkit part is securely packed in a customized kit box, to keep it in like-new condition even when stored for long periods of time.

Also, inquire about our ECO Express Program. If you have an emergency, our Express Service Team can get you back up and running within 48 hours or less.

## **PULSAFEEDER**

### **A Unit of IDEX Corporation**

2883 Brighton-Henrietta Town Line Road  
Rochester, NY 14623  
716-292-8000/FAX 716-424-5619  
<http://www.pulsa.com>  
e-mail: [pulsa@pulsa.com](mailto:pulsa@pulsa.com)

"ECO" and "GEARCHEM" are registered trademarks of PULSAFEEDER, Inc.

Grafoil is a registered trademark of Crane Packing Company.

Teflon is a registered trademark of E.I. DuPont Company.



**IDEX**  
IDEX CORPORATION